

TABLE OF CONTENTS

1. INTRODUCTION AND SYSTEM DESCRIPTION	4
2. SPECIFICATIONS	5
2.1 CURRENT CAPACITY:	5
2.2 VOLTAGE MEASUREMENT CAPACITY:	5
2.3 VOLTAGE SOURCE:	5
2.4 SHUNT:	5
2.5 METERS:	5
2.6 STATUS INDICATORS:	5
2.7 CONTROLS:	6
2.8 CONNECTORS:	6
2.9 FUSES:	6
2.10 LINE VOLTAGE:	6
2.11 ENVIRONMENTAL:	6
3. CONTROLS AND DISPLAYS	7
3.1 Front Panel:	7
3.2 Rear Panel:	9
4. OPERATING INSTRUCTIONS	11
4.1 Superseder/MasterCharger Voltage and Current monitoring:	11
4.2 Superseder/MasterCharger Voltmeter testing/calibration:	11
4.3 Superseder/MasterCharger Voltage cut-off testing and calibration:	12
4.4 Superseder/MasterCharger Ammeter calibration:	12
4.5 Superseder/MasterCharger Temp-Plate simulation:	13
4.6 SupersederXG/SuperMasterCharger Temp-Plate simulation:	13
5. VERIFICATION OF PERFORMANCE AND CALIBRATION	15
5.1 METERS CIRCUIT BOARD:	15
5.2 CALIBRATOR CIRCUIT BOARD:	17
5.3 TEMP-PLATE SIMULATOR:	18
6. TROUBLESHOOTING	19
6.1 DOES NOT TURN ON:	19
6.2 NO VOLTMETER READING WITH A BATTERY CONNECTED:	19
6.3 CANNOT READ CURRENT OR VOLTAGE THROUGH THE FRONT PANEL BINDING POSTS:	19

- 6.4 CANNOT OBTAIN AN OUTPUT FROM THE Calibrator: 19
- 6.5 VOLTMETER INDICATES A READING WITHOUT A BATTERY CONNECTED: 19
- 6.6 OUTPUT VOLTAGE AT MAXIMUM AT OVER 100V. CANNOT BE ADJUSTED: 19
- 7. LINE VOLTAGE CHANGE 20
 - 7.1 Remove the line cord. 20
 - 7.2 Remove the plate that covers the power block (Rear Panel)..... 20
 - 7.3 Remove the line voltage selector plug-in board and re-install with the indicator on 220V..... 20
 - 7.4 Remove the fuse holder and replace the 0.5A SB fuse with a 0.25A SB fuse..... 20
 - 7.5 Re-install the cover and line cord..... 20
- 8. WIRING DIAGRAM..... 21
- 9. REPLACEABLE MODULES AND PARTS 22
 - 9.1 Calibrator Circuit Board – P/N 9879010003 22
 - 9.2 Meters Board – P/N 9879101001 22
 - 9.3 Dual Supply Board – P/N 9879109004 22
 - 9.4 Voltage Selector (10 turn, 100K potentiometer) – P/N 4753101040 22
- 10. DISCLAIMER 23
 - 10.1 This Calibrator is a precision instrument intended to be operated by personnel qualified in the servicing of aircraft, industrial or medical batteries. 23
 - 10.2 JFM Engineering’s responsibility is limited to the repair/replacement of any malfunctioning part of the system (not responsible for any losses incurred from the usage of the system)..... 23
 - 10.3 User’s Responsibility 23
- 11. REVISION INDEX 24

TABLE OF FIGURES

Figure 1 – Front View 8
Figure 2 – Rear View..... 10
Figure 3 – Battery Temperature Screen 14
Figure 4 – Ambient Temperature Screen..... 14
Figure 3 – Meters Board Adjustments 16
Figure 4 – Calibrator Board Adjustments 16

TABLE OF TABLES

Table 1 - Index of Revisions..... 24

1. INTRODUCTION AND SYSTEM DESCRIPTION

- The Calibrator is a precision instrument that is part of a system aimed at improving the accuracy and efficiency in the process of battery testing and certification
- The Calibrator is designed to verify the performance and to calibrate Battery Charger-Analyzers used on Nickel-Cadmium, Lead-Acid and other types of batteries. It is principally designed for the Superseder/MasterCharger¹ line of battery test instruments but it can also be applied to other types of chargers and charger-analyzers.
- The instrument is basically a digital Ammeter and Voltmeter that is connected between the charger under test and the battery. In addition, it provides a low current adjustable voltage source to simulate the various battery voltage cut-off points and a Temp-Plate simulator to test the battery overtemp portion of the Superseder/MasterCharger line of Charger-Analyzers.
- Two 3-1/2 digit LED meters provide the simultaneous monitoring of voltage and current on the charger and battery under test. The voltmeter can also be used independently by way of the two external meter lead jacks.
- Current and voltage measurement can be performed through the external cables, fitted with a Battery Cable Plug and a Battery Receptacle, or through the front panel binding posts, for other types of tests at reduced currents.

¹ Also applicable to the new Intelligent Charger-Analyzers (SupersederXG, 24-400xg, SuperMasterCharger, and miniMasterCharger)

2. SPECIFICATIONS

2.1 CURRENT CAPACITY:

2.1.1. Through the rear cables: 50A max, continuous, 100A max (intermittent).

2.1.2. Through the front panel binding posts: 10A max.

2.2 VOLTAGE MEASUREMENT CAPACITY:

2.2.1. 0 to 20V (19.90V) or 0 to 200V (199.9), internal or external.

2.3 VOLTAGE SOURCE:

2.3.1. Externally adjustable: 0 to 100V, 25mA max.

2.4 SHUNT:

2.4.1. 1mV/A (200mV/200A), 0.25% accuracy.

2.5 METERS:

Type: LED, 3-1/2 digit.

2.5.1. Voltage: 0 to 19.9V and 0 to 199.9V.

Accuracy: 0.25% of reading, ± 1 digit.

2.5.2. Current: 0 to 199.9A

Accuracy: 0.5% of reading 1 digit.

2.6 STATUS INDICATORS:

2.6.1. Calibrator on-line, connected to the charger under test (rear/front posts).

2.7 CONTROLS:

- 2.7.1. Voltmeter source and scale selector.
- 2.7.2. Potentiometer for calibrator voltage adjustment.
- 2.7.3. Calibrator ON LINE/OFF (connected to the output/disconnected) selector switch.
- 2.7.4. Calibrator polarity (normal and reverse) selector switch.
- 2.7.5. Thermistor selector switch.
- 2.7.6. Thermistor temperature simulator selector switch.
- 2.7.7. Power ON/OFF switch (on the rear power block).
- 2.7.8. Line voltage selector (on the rear power block).

2.8 CONNECTORS:

- 2.8.1. Front panel binding posts (fused).
- 2.8.2. External voltmeter meter banana jacks.
- 2.8.3. Rear posts with cables with battery connectors.
- 2.8.4. Shunt monitor banana jacks.
- 2.8.5. Temp-Plate simulator cable connector.

2.9 FUSES:

- 2.9.1. Power: 0.5A slow-blow (0.25A for 230V operation).
- 2.9.2. Output: 12A, slow-blow (for the front panel binding posts).

2.10 LINE VOLTAGE:

115/230VAC \pm 10%, 50-60Hz.

2.11 ENVIRONMENTAL:

5° C to 35° C.

3. CONTROLS AND DISPLAYS

3.1 Front Panel:

M1	Ammeter Display
M2	Voltmeter Display
DS1	Calibrator output on-line Indicates that the Calibrator is connected to the charger (rear/front posts) to simulate the battery.
J1	Calibrator output (+) Separate, independent output
J2	Calibrator output (-) Separate, independent output

NOTE: There is always a voltage present at the Calibrator jacks (as set by the potentiometer). This output can be used to test other units, independent of the Charger/Battery connections to the Calibrator (provided that the Calibrator is not on-line). Maximum current is 20mA.

SW1	Calibrator on-line/off selector switch.
SW2	Calibrator polarity normal/reverse selector switch.
SW3	Voltmeter Source and Scale Selector
R1	Calibrator voltage adjustment potentiometer.
J3	Charger Input (+)
J4	Charger Input (-)
J5	External Voltmeter Input (+)
J6	External Voltmeter Input (-)
J7	Output to the Battery (+)
J8	Output to the Battery (-)

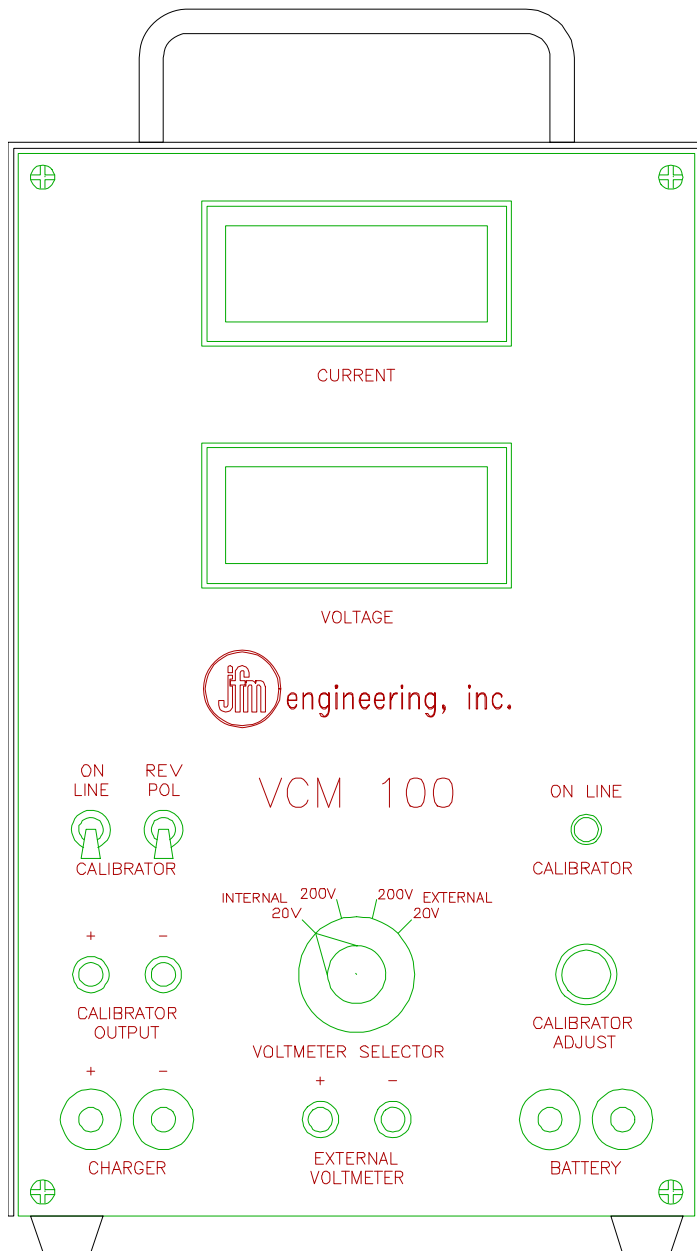

Figure 1 – Front View

3.2 Rear Panel:

F1	Calibrator Output Fuse (0.25A) Protects the Calibrator output circuit in case of connection to a negative voltage.
SW4	Temp-Plate Temperature Simulator Selector switch.
SW5	Thermistor Selector switch.
J9	Thermistor Monitor (+)
J10	Thermistor Monitor (-)
J11	Temp-Plate Simulator Connects to the Temp-plate cable in the Superseder Battery Cable.
J12	Shunt Monitor (+) Reads the Shunt output.
J13	Shunt Monitor (-) Reads the Shunt output.
J14,SW6	Power Entry Block Combined line cord receptacle, line voltage selector, line fuse(s) and power on-off switch.
F2	Shunt Fuse (12A SB). For protection while using the front panel jacks only.
(+)	Input. Connection to the Charger (-).
(-)	Input. Connection to the Charger (-) (common).
(+)	Output. Connection to the Battery (+).
(-)	Output. Connection to the Battery (-) (common).

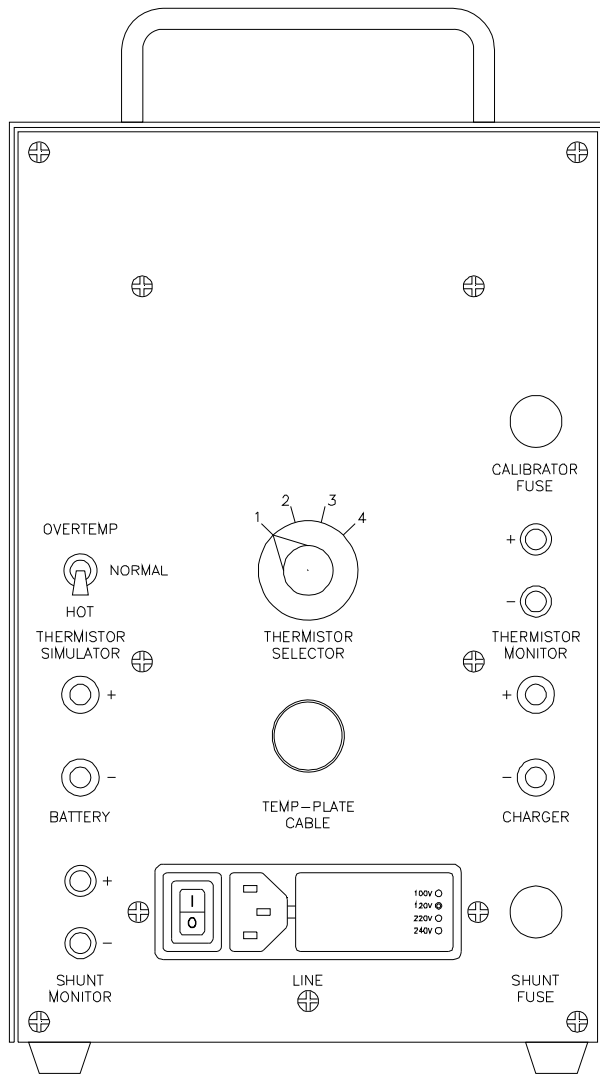

Figure 2 – Rear View

4. OPERATING INSTRUCTIONS

NOTE: *Do not use the front panel and rear panel current connections at the same time.*

NOTE: *Do not connect to a battery if the Calibrator output is set on-line.*

NOTE: *Connect or disconnect only with the Charger-Analyzer in RESET.*

4.1 Superseder/MasterCharger Voltage and Current monitoring:

4.1.1. Set the Calibrator voltmeter selector to INTERNAL 200V and the calibrator ON LINE and REV POL switches to off (down).

4.1.2. Connect one ELCON connector on the Superseder Battery Cable to the receptacle at the charger side of the Calibrator. Short the remaining ELCON on the Battery Cable (on the Temp-Plate).

4.1.3. Connect the ELCON connector on the Calibrator to the battery.

NOTE: Other than voltmeters, make no connections to the binding posts on the front panel of the instrument while the output cables are in use.

4.1.4. The voltmeter will indicate battery voltage. Verify that the reading on the Superseder matches the reading on the Calibrator.

NOTE: Exact Voltmeter readings must be done with no current flow to eliminate the errors due to voltage drops on the Superseder cables and shunt and cables on the Calibrator.

4.1.5. Start the Superseder and verify its current readings against the Calibrator.

4.2 Superseder/MasterCharger Voltmeter testing/calibration:

4.2.1. Refer to the calibration instructions in the Superseder manual.

4.2.2. Connect the calibrator output jacks of the Calibrator to the Superseder external voltmeter jacks.

4.2.3. Set the voltmeter selector on the Calibrator to Calibrator 200V.

4.2.4. Adjust the calibrator output to obtain the required voltage.

4.2.5. Calibrate the voltmeter as required.

4.3 Superseder/MasterCharger Voltage cut-off testing and calibration:

NOTE: No battery connection for this test.

- 4.3.1. Refer to the calibration instructions in the Superseder manual.
- 4.3.2. Connect the calibrator cable to the Superseder battery cable (Short the remaining connector on the battery cable).
- 4.3.3. Set the Superseder current selectors to zero. (MAIN and TOPPING).
- 4.3.4. Set the voltmeter selector on the Calibrator to INTERNAL 200V and the calibrator ON LINE to on (up). The REV POL switch is used normal position (down) except when a reverse polarity test is called for.
- 4.3.5. Adjust the calibrator output voltage as required to test/calibrate the Superseder Open Circuit, Reverse Polarity, Overvoltage and Discharge Cut-Off functions.

4.4 Superseder/MasterCharger Ammeter calibration:

- 4.4.1. Refer to the calibration instructions in the Superseder Manual.
- 4.4.2. Set the calibrator ON LINE to off (down) and the voltmeter selector to INTERNAL 200V.
- 4.4.3. Connect the Calibrator to the Superseder and to a battery.
- 4.4.4. Start the Superseder and adjust the charging current to the required level. Test/Calibrate the Superseder ammeter as required.
- 4.4.5. Verify readings on discharge.

4.5 Superseder/MasterCharger Temp-Plate simulation:

Note: The Charger-Analyzer must be running in Charge Mode to test this functionality.

- 4.5.1. Connect the Temp-plate end of the Superseder Battery Cable to the Calibrator.
 - 4.5.1.1. The Superseder red OVERTEMP light must turn-off.
- 4.5.2. Set the Thermistor simulator to HOT.
 - 4.5.2.1. No alarm indication must occur.
- 4.5.3. Set the Thermistor simulator to OVERTEMP.
 - 4.5.3.1. The alarm must sound.
- 4.5.4. The following voltages must be registered at the Calibrator Thermistor monitor jacks:
 - 4.5.4.1. NORMAL: $7.5V \pm 0.15V$
 - 4.5.4.2. HOT: $6.36V \pm 0.127V$
 - 4.5.4.3. OVERTEMP: $6.23V \pm 0.124V$

4.6 SupersederXG/SuperMasterCharger Temp-Plate simulation:

Note: The Charger-Analyzer must be running in Charge Mode to test this functionality.

- 4.6.1. Connect the Temp-plate input in the rear of the Charger-Analyzer to the Calibrator.
- 4.6.2. Set the Thermistor simulator to HOT.
 - 4.6.2.1. No alarm indication must occur.
- 4.6.3. Set the Thermistor simulator to OVERTEMP.
 - 4.6.3.1. The alarm must sound.

- 4.6.4. The following voltages must be registered at the Calibrator Thermistor monitor jacks:
- 4.6.4.1. NORMAL: $3.75V \pm 0.08V$
 - 4.6.4.2. HOT: $3.18V \pm 0.06V$
 - 4.6.4.3. OVERTEMP: $3.11V \pm 0.06V$
- 4.6.5. The following temperatures must be registered at the LCD Screen of the Charger-Analyzer (VIEW 5 – Temp-Plate Temps)
- 4.6.5.1. NORMAL: $25^{\circ}C \pm 0.5^{\circ}C$
 - 4.6.5.2. HOT: $37.8^{\circ}C \pm 0.8^{\circ}C$
 - 4.6.5.3. OVERTEMP: $39.3^{\circ}C \pm 0.8^{\circ}C$
 - 4.6.5.4. VIEW-5
External Battery Temperatures (Temp-Plate)

TO	MO	00:00:00	NO
TEMP-PLATE TEMPS			
B1=25.0C	B3=25.0C		
B2=25.0C	B4=25.0C		

Figure 3 – Battery Temperature (Temp-Plate) Screen

- 4.6.6. The following temperatures must be registered at the LCD Screen of the Charger-Analyzer (VIEW 5 – Temp-Plate Temps)
- 4.6.6.1. AMBIENT $25^{\circ}C \pm 0.5^{\circ}C$
 - 4.6.6.2. VIEW-6
Ambient Temperature and Auxiliary Input (TBD)

TO	MO	00:00:00	NO
AMB=25.0C	AUX=0000		

Figure 4 – Ambient Temperature Screen

5. VERIFICATION OF PERFORMANCE AND CALIBRATION

NOTE: Verify performance every 6 months. Calibrate every 12 months.

NOTE: Verify performance first by executing the tests without the adjustments. Proceed with adjustments when the tests indicate a deviation.

5.1 METERS CIRCUIT BOARD:

5.1.1. Voltmeter:

- 5.1.1.1. Set the voltmeter selector to EXT 20V.
- 5.1.1.2. Connect a DC voltage source (power supply) to the External Voltmeter Jacks and to an external reference voltmeter.
- 5.1.1.3. Set the voltage source for a voltage between 19 and 20V and adjust R17 to match the reading on the Calibrator.
- 5.1.1.4. Verify tracking by comparing readings at other voltages between 0V and 20V (e.g. every 5V).
- 5.1.1.5. Set the scale to EXT 200V. Verify readings at various voltages between 0V and 200V (or 100V).
- 5.1.1.6. *NOTE: The 200V scale is generated by a divider. No adjustment is available.*

5.1.2. Ammeter:

- 5.1.2.1. With no input or load connections adjust R3 for a zero reading on the Calibrator.
- 5.1.2.2. NOTE 1: Newer versions of this circuit board no longer have a zero adjustment.
- 5.1.2.3. NOTE 2: Modified versions of this circuit board may not have a zero adjustment (adjustment not required).
- 5.1.2.4. Connect a Charger to the input (charger) side of the Calibrator and connect the output (battery) side to a battery through a reference ammeter or shunt. A high current power supply and a suitable load can also be used in place of a charger and a battery.
- 5.1.2.5. Set the Charger (or Power Supply) for a current of 50A (40A minimum) and adjust R10 to match the reading on the Calibrator
- 5.1.2.6. Verify tracking by comparing readings at other currents.

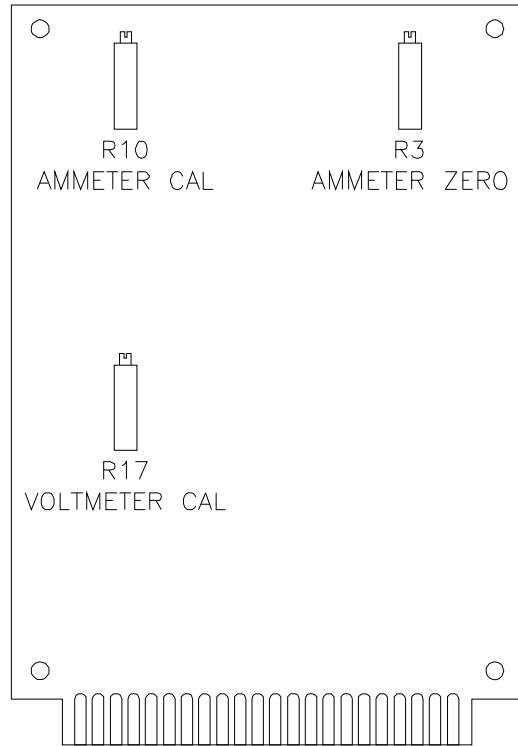

Figure 5 – Meters Board Adjustments

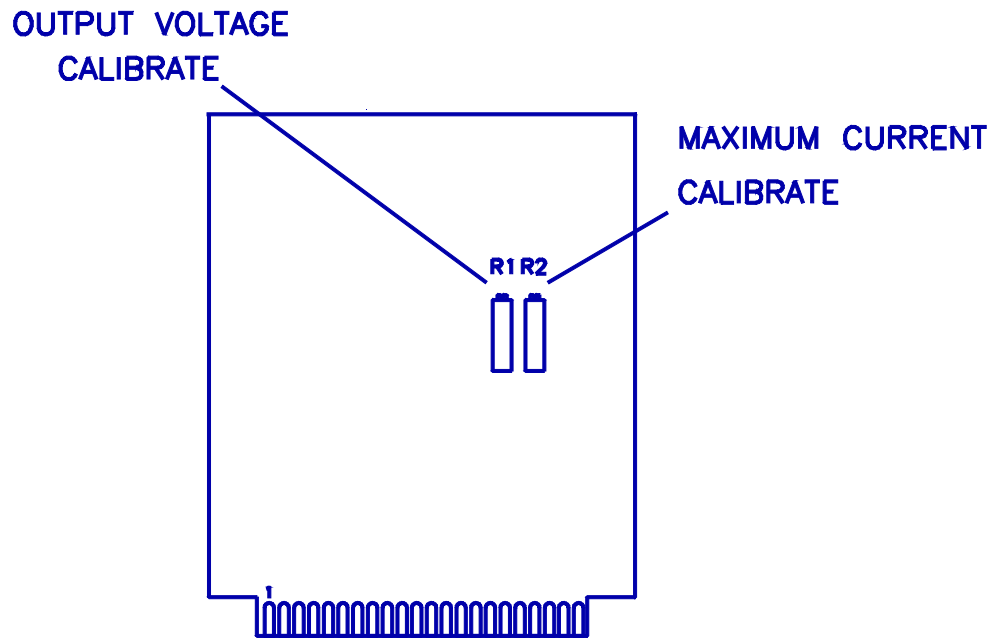

Figure 6 – Calibrator Board Adjustments

5.2 CALIBRATOR CIRCUIT BOARD:

5.2.1. Maximum Voltage:

Note: This adjustment is only for range setting (not critical).

5.2.1.1. Connect the output of the Calibrator to a reference voltmeter.

5.2.1.2. Set the Voltage Adjustment Potentiometer (Calibrator front panel) to maximum (CW)

5.2.1.3. Adjust R1 for an output of 100.0V.

5.2.2. Maximum Current:

Note: This adjustment is only for protection (not critical).

5.2.2.1. Set the calibrator output for 50.0V

5.2.2.2. Connect a 2K-ohm, 5W resistor (for 25mA) or a 2.5K-ohm resistor (for 20mA) to the output of the calibrator.

5.2.2.3. Adjust R2 (increase the current) to insure that the output remains at 50.0V when loaded by the resistor.

5.3 TEMP-PLATE SIMULATOR:

5.3.1. Resistance test:

5.3.1.1. Measure with an Ohm-Meter at the Thermistor monitor (no connection to the Charger-Analyzer).

- Normal: 30.1K-ohm, $\pm 1\%$ (301 Ohms).
- Hot: 17.5K-ohm, $\pm 1\%$ (175 Ohms).
- Overtemp: 16.5K-Ohm, $\pm 1\%$ (165 Ohms).

5.3.2. Active test, Superseder and MasterCharger:

Note: for reference only (these results are based on a 10K, 1% resistor pulling-up to +10V at the Charger-Analyzer side).

5.3.2.1. Measure with a Voltmeter at the Thermistor monitor with the Temp-plate cable connected to the Superseder/MasterCharger (with power on).

- Normal: 7.5V, $\pm 0.15V$
- Hot: 6.36V, $\pm 0.127V$
- Overtemp: 6.23V, $\pm 0.124V$

5.3.3. Active test, SupersederXG and SuperMasterCharger:

Note: for reference only (these results are based on a 10K, 1% resistor pulling-up to +5V at the Charger-Analyzer side).

5.3.3.1. Measure with a Voltmeter at the Thermistor monitor with the Temp-plate cable connected to the Superseder/MasterCharger (with power on).

- NORMAL: 3.75V $\pm 0.08V$
- HOT: 3.18V $\pm 0.06V$
- OVERTEMP: 3.11V $\pm 0.06V$

6. TROUBLESHOOTING

- 6.1 DOES NOT TURN ON:
 - 6.1.1. Unit not plugged in.
 - 6.1.2. Open line fuse.
 - 6.1.3. Problems with the Power Supplies.
- 6.2 NO VOLTMETER READING WITH A BATTERY CONNECTED:
 - 6.2.1. Voltmeter not on internal.
- 6.3 CANNOT READ CURRENT OR VOLTAGE THROUGH THE FRONT PANEL BINDING POSTS:
 - 6.3.1. Open Shunt fuse.
- 6.4 CANNOT OBTAIN AN OUTPUT FROM THE Calibrator:
 - 6.4.1. Open Calibrator fuse.
- 6.5 VOLTMETER INDICATES A READING WITHOUT A BATTERY CONNECTED:
 - 6.5.1. Calibrator set to on-line or voltmeter set to calibrator.
- 6.6 OUTPUT VOLTAGE AT MAXIMUM AT OVER 100V. CANNOT BE ADJUSTED:
 - 6.6.1. Shorted output transistor.
 - 6.6.2. Damaged output voltage selector (potentiometer)
 - 6.6.3. Damaged regulator circuit

7. LINE VOLTAGE CHANGE

Change from 115V to 230V operation.

7.1 Remove the line cord.

7.2 Remove the plate that covers the power block (Rear Panel).

7.3 Remove the line voltage selector plug-in board and re-install with the indicator on 220V.

7.4 Remove the fuse holder and replace the 0.5A SB fuse with a 0.25A SB fuse.

NOTE: If both sides of the line must be fused, reverse the fuse holder and install two miniature 0.25A fuses. Re-install the fuse holder.

7.5 Re-install the cover and line cord.

8. WIRING DIAGRAM

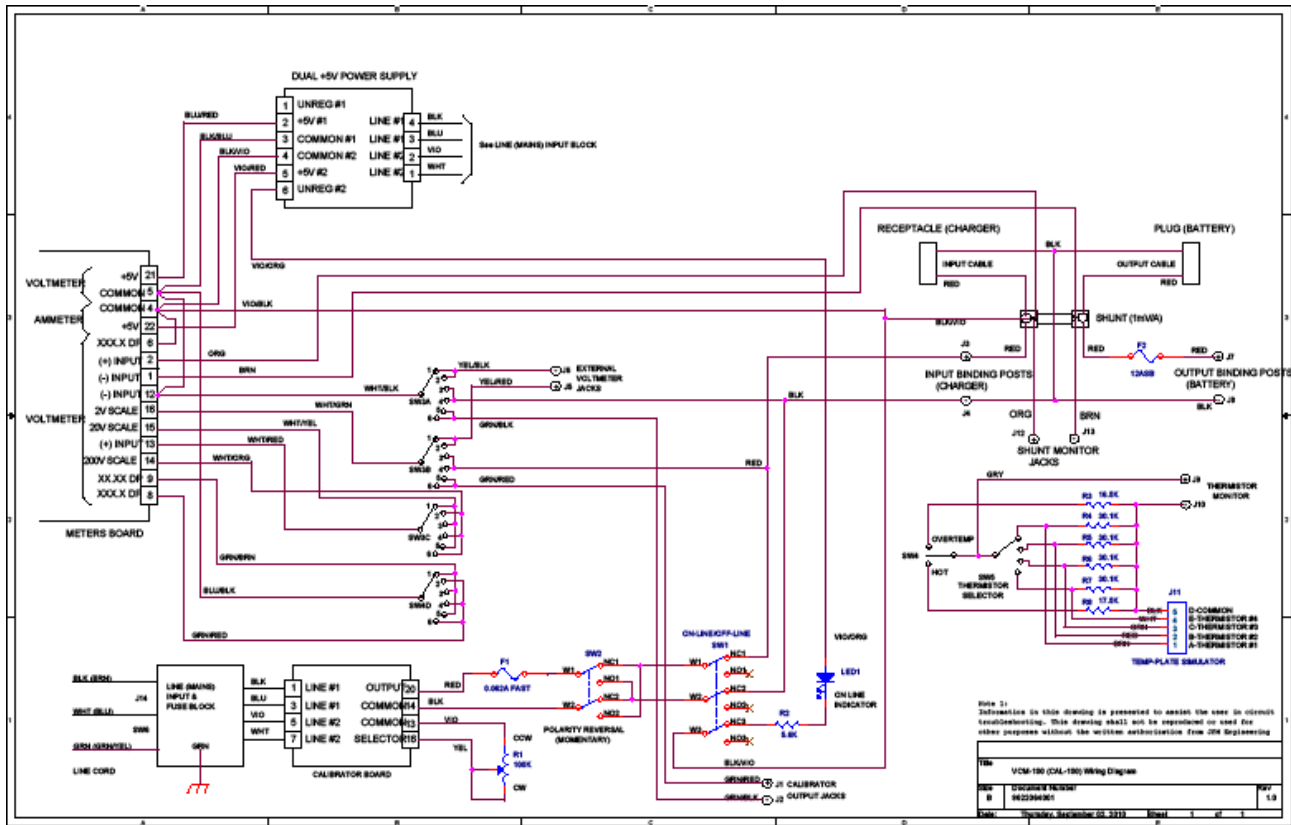

9. REPLACEABLE MODULES AND PARTS

9.1 Calibrator Circuit Board – P/N 9879010003

9.2 Meters Board – P/N 9879101001

9.3 Dual Supply Board – P/N 9879109004

9.4 Voltage Selector (10 turn, 100K potentiometer) – P/N 4753101040

10. DISCLAIMER

10.1 This Calibrator is a precision instrument intended to be operated by personnel qualified in the servicing of aircraft, industrial or medical batteries.

10.2 JFM Engineering's responsibility is limited to the repair/replacement of any malfunctioning part of the system (not responsible for any losses incurred from the usage of the system).

10.3 User's Responsibility

- It is the user's responsibility to verify suitability in the intended application.
- It is the user's responsibility to verify the performance of the instruments and to operate and maintain it in accordance with the above given instructions.
- It is the user's responsibility to calibrate the Charger-Analyzers in accordance with the instructions and recommendations of the manufacturers of the Charger-Analyzer.
- It is the user's responsibility to operate the Instrument within standard safety procedures applicable to the operation of a Battery Test Facility.
- It is the user's responsibility to install power receptacles and wiring in accordance with local wiring codes.
- It is the user's responsibility to verify the integrity of the performance of this instrument in accordance with the instructions of Section [5].
- It is the user's responsibility to operate this instrument within the limits and guidelines as described in the Precautions and Installation Sections [4]
- It is the user's responsibility to properly package the instrument for shipping whenever factory service is required.

11. REVISION INDEX

Table 1 - Index of Revisions

REVISION	DATE	NOTES
1.0	24 May 1990	Released
1.1	29 August 1994	Re-type, additional figures
1.1.1	26 August 1997	Re-type
1.2	22 December 2000	Re-type
2.0	20 June 2005	Document re-format
3.0	16 January 2010	Document re-format, text updates, figures updates
3.1	25 February 2011	Paragraph 5.1.2.5: R10 was R17 Page 20: added wiring diagram
3.2	4 March 2011	Added section 4.6 Edited section 5.2